

Proscend 180-T



Description

Proscend 180-T is a VDSL2 SFP modem that interconnects with Gateway Processor by using a MSA (MultiSource Agreement) compliant hot pluggable electrical interface. The DSL chipset inside the VDSL2 SFP modem supports all VDSL2 profiles and ensures its interoperability with all existing broadband network services.

As broadband access technology has evolved rapidly, Service Providers need to upgrade their broadband network service every few years. Traditionally, Service Providers have replaced the entire CPE device in order to provide subscribers with faster Internet services. Not only does it increase their CAPEX and OPEX but also wastes resources and increase inventories. Leveraging **Proscend 180-T** VDSL2 SFP series in Service Providers' product portfolio will help them significantly reduced the software porting and testing effort and shorten their product time-to-market.

Proscend 180-T VDSL2 SFP modem realizes the modulation of VDSL2 broadband access. It can be integrated with routers, switches or residential gateways that are equipped with a SFP type of WAN interface. There's no more need for Service Providers to maintain more than one type of CPE device in the field or in the warehouse, moreover, this also can give them the possibility to future upgrade. Users can upgrade to any broadband access data rate easily only by plugging in different type of WAN SFPs such as VDSL2 35b/G.fast or optical TRx SFPs with the same internet box and user interface.

Features

- Support all VDSL2 profiles
- MSA compliant hot pluggable electrical interface
- Wide -20°C to 75°C temperature range.

MECHANICAL DIMENSIONS

(Units in mm)

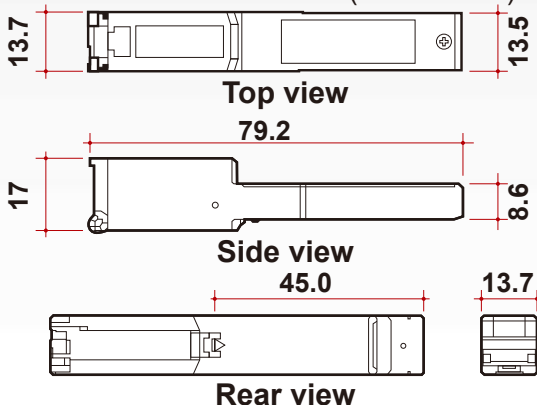

APPLICATION BLOCK DIAGRAM

Residential Gateway with SFP type of WAN template

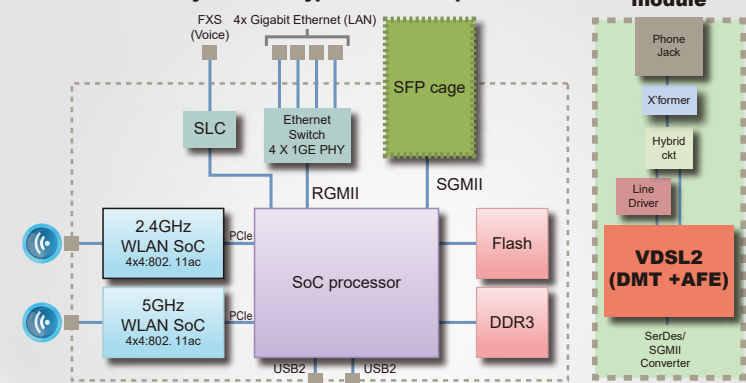



Proscend 180-T

Key features

VDSL2 Transmission modes		ADSL2+ Transmission modes		Advanced Features from ITU	
VDSL2 profiles	8a, 8b, 8c, 8d, 12a, 12b, 17a, 30a	Annex	A/B/M	ROC	Supports Robust Overhead Channel
Data rate	Up to 100 Mbps upstream / 100 Mbps downstream	Data rate	Up to 24 Mbps	Dual latency	Supported
Annex	A/B/C	Modes	PTM & ATM (AAL5 and OAM cells)	OLR	Supports bit swapping, SRA, SoS and dynamic Interleaver depth (D) change
Parameter	997.1 Compliant	PVC	Up to 8 PVCs	US0	Supported
Configurability	Implement the system setting via the EBM program	VC	Up to 65k VCs	PBO	Both UPBO and DPBO supported
Other Unique Features					
Booting	Serial Flash	QoS	Flexible packet sorting based on Ether Type, VLAN ID or VLAN priority (supports QinQ).		

Specifications

Hardware		RJ-45 female connector (Fully compatible with RJ-11 male connector)
		SGMII/ SERDES connect to host
		LED 1 (Remain Undefined)
		LED 2 (PWR/ Link Status indicator)
Software		Self Boot & Managed by Internal Flash
		Support Ethernet Boot & Management
Power Requirement		2.1 W
Power Supply		3.3 V
Environment	Operating Temperature	-20 ~ +75°C (SFP cage)
	Storage Temperature	-20 ~ +85°C
	Operating Humidity	10% to 90% (non-condensed)
	Storage Humidity	5% to 95% (non-condensed)
	Surge Protection	2KV
Certification		CE / FCC

Order information

Model No.	Description	Connector
180-T	VDSL2 SFP Modem	RJ-45 / RJ-11

Proscend reserves the right to change specifications without prior notice. All brand names and trademarks are property of their respective owners. All rights reserved.

2F, No.36, Industry East Road IV, Hsinchu Science Park, Hsinchu, Taiwan. 300
Tel: +886-3-5639000 Fax: +886-3-5633830 Email: sales@proscend.com

PROSCEND[®]
Proscend Communications Inc.
www.proscend.com